





FEATURES:

Relative Clamping Force*	
Relative Retention Force*	
Relative Thermal Resistance*	
Relative Price	
*For mechanical and thermal performance data see the Technical Applications section pages 77-94	

WEDGES

Material:

Aluminum Alloy
6061-T6 QQ-A-200/8

Finish:

See finish table on opposite page

SCREW

.09 in or 2.5 mm hex. socket head cap screw, depending on mounting configuration

Material:

Stainless Steel
QQ-S-763, ASTM A 582

Finish:

Passivate per MIL-S-5002

WEIGHT

.080 oz/in
(0.89 gm/cm)

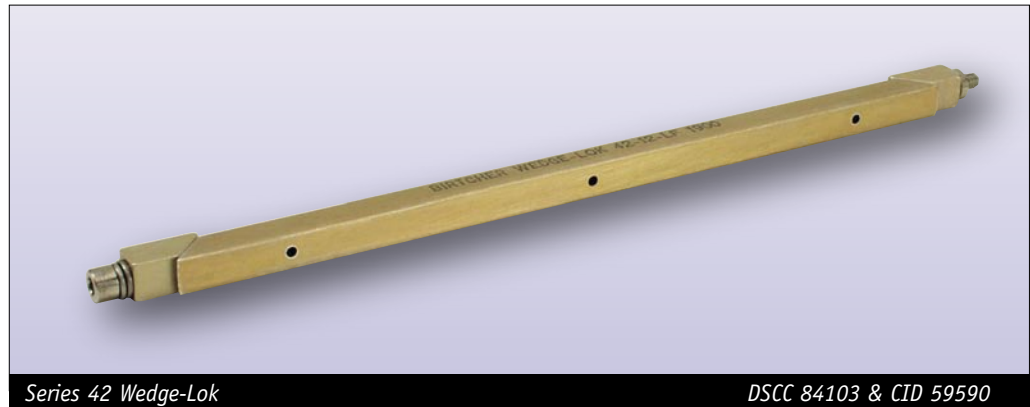

**DESIGNED FOR HEAVY SHOCK,
VIBRATION & HEAT DISSIPATION**
.225(5.72) X .225(5.72) PROFILE

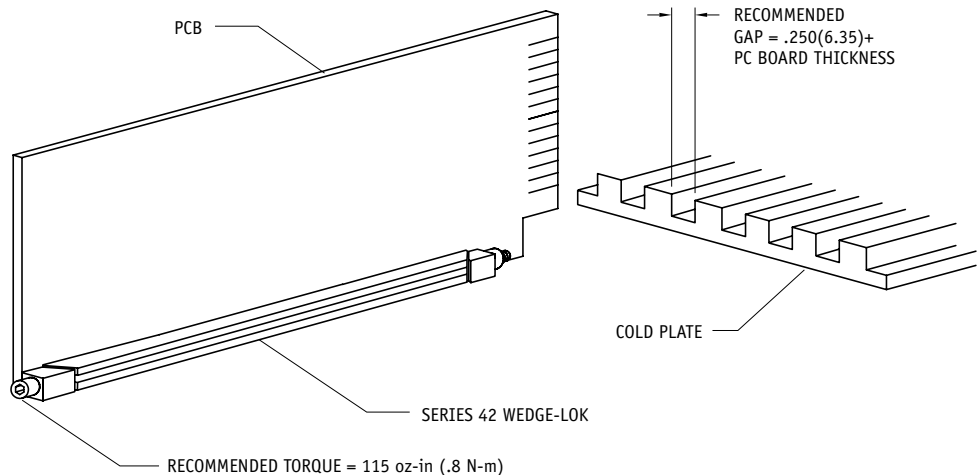
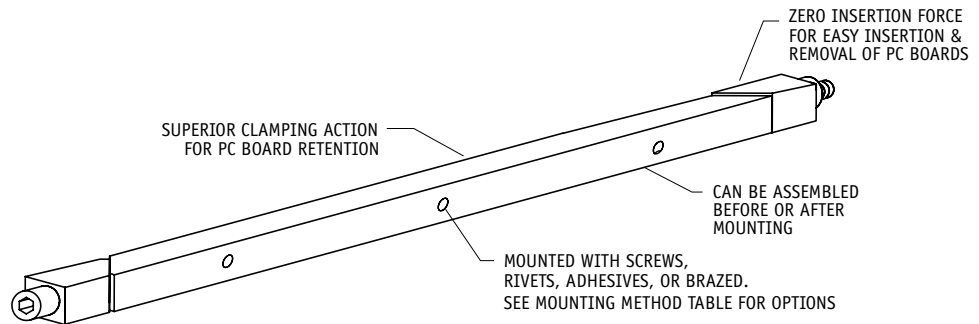

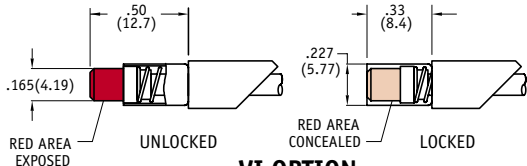

VI OPTION

Indicates assembly is unlocked
(adds .19 (4.8) to screw length)

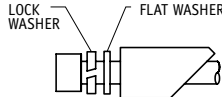

LF OPTION

Provides additional resistance to shock and vibration (adds .06 (1.5) to screw length)

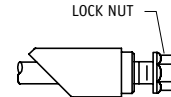

LN OPTION

Captivates rear wedge when untorqued (adds .10 (2.5) to screw length)

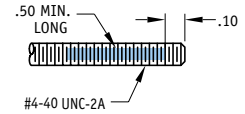

L OPTION

Provides additional resistance to shock and vibration

NOTE ON DIMENSIONS:
ENGLISH LISTED FIRST
FOLLOWED BY METRIC
IN PARENTHESES

TOLERANCES:
UNLESS OTHERWISE SPECIFIED
.XXX(.XX) = .01(.25)
.XX(.X) = .02(.50)

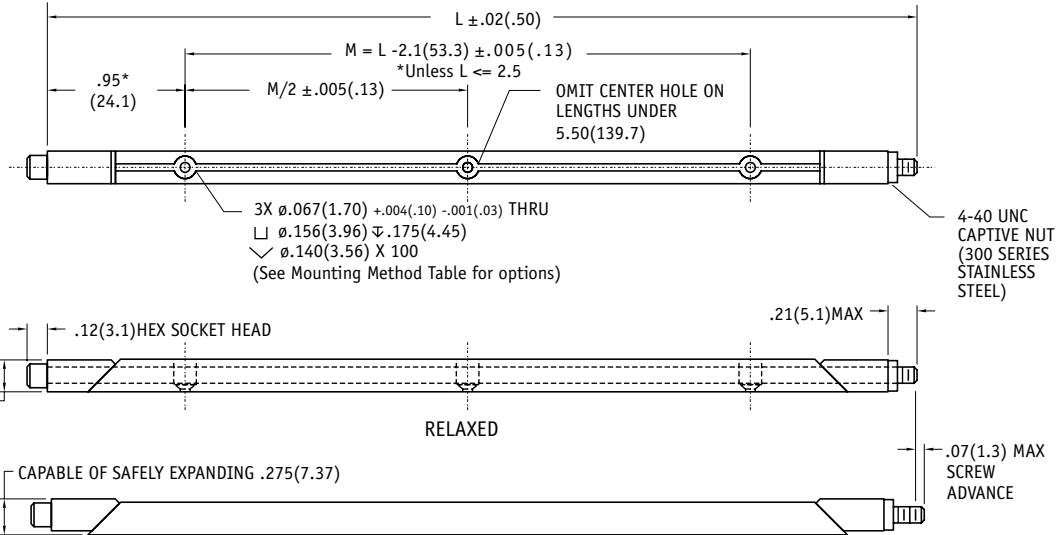

COUNTERBORE .156(3.96) X .175(4.45) DEEP
.069(1.75) HOLE COUNTERSINK 100 X .140(3.56)
(See Mounting Method Table for options)

Part Number Code (See example below)

Series 42 Wedge-Lok Three-piece 42 X -X -X -X -X -X

Optional Visual Indicator

Visual Indicator _____ **VI**

None _____ **[Blank]**

Length

In 1/2" increments _____ -4 (2") and up

In 12.7mm increments _____ -4 (50.8mm) and up

Finish

Chem Film _____ **[Blank]**

or select code letter from Finish Table ① _____

Nuts and Washers

Lock Washer and Flat Washer _____ **LF**

None _____ **[Blank]**

Lock Nut _____ **LN**

None _____ **[Blank]**

Mounting

Standard Rivet Holes _____ **[Blank]**

or select code letter from Mounting Method Table ② _____

Lock Patch

Lock Patch _____ **L**

None _____ **[Blank]**

① FINISH TABLE

Code Letter	Finish (see pg.9 for RoHS Compliance)
NONE	Chemical Film per MIL-C-5541, Class 1A, Gold, non RoHS compliant
CC	Chemical Film per MIL-C-5541, Class 1A, Clear
EN	Electroless Nickel per MIL-C-26074, Class 4, Grade B, Bright
N	Nickel Plate per QQ-N-290, Class 1, Grade G, Bright (.0002")
B	Black Anodize per MIL-A-8625, Type II, Class 2, (.00005" - .0003")
B3	Hard Black Anodize per MIL-A-8625, Type III, Class 2 (.002")
B3D	Hard Black Anodize with Dry Film Lube per MIL-L46010

② MOUNTING METHOD TABLE

Code Letter	Method
NONE	Rivet Mount (ø.067 (1.70)) holes with counterbore and countersink
S	Screw #2-56 UNC-2B
T	Screw #0-80 UNF-2B
M2	Screw M2 x .40 metric
M	Screw M2.5 x .45 metric
P	Indexing Pins ø.062 x .040" (two pins only)

Indexing pins (-P) and rivet (NONE) parts are shipped unassembled. Center wedge is unplated and unmarked for Indexing Pin (-P) Method.

**FOR MECHANICAL AND THERMAL PERFORMANCE
SEE THE TECHNICAL APPLICATIONS SECTION PAGES 77-94**

Part Number Code example: 42VI-10-B3D-LF

Series 42 Wedge-Lok Three-piece, 5 in(127mm) long, hard black anodize finish with dry film lube, with Lock Washer and Flat Washer option, standard rivet hole mounting.