





**FEATURES**

|                              |   |
|------------------------------|---|
| Relative Clamping Force*     |  |
| Relative Retention Force*    |  |
| Relative Thermal Resistance* |  |
| Relative Price               |  |

**CHANNEL, WEDGES AND END PIECES**

**Material:**

Aluminum Alloy 6061-T6 per ASTM-B-221

**Finish:**

See finish table on opposite page

**SCREW & WASHERS**

.09 in or 2.5 mm hex. socket head cap screw, depending on mounting configuration

**Material:**

Stainless Steel (300 Series) per QQ-S-763 ASTM-A-582

**Finish:**

Passivated per MIL-S-5002 Type II

**WEIGHT**

.115 oz/in  
(1.28 gm/cm)

Patent no. 4,823,951

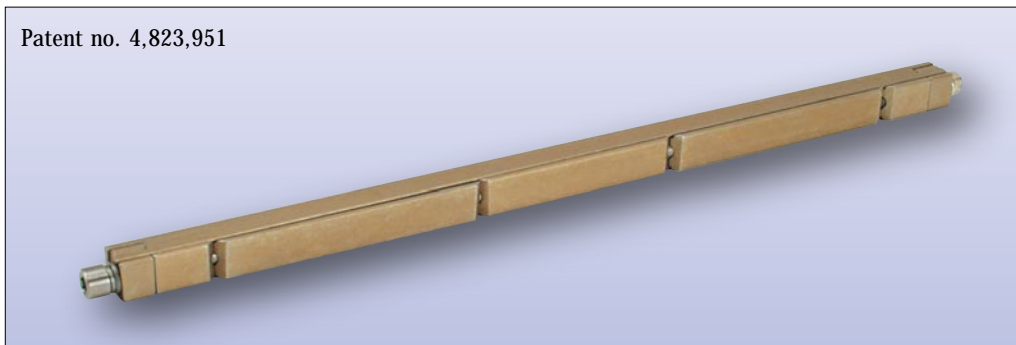

Series 48SL Wedge-Lok

Also 47SL version available (.225 x .225) call factory for details

**DESIGNED FOR HEAVY SHOCK, VIBRATION, & HEAT DISSIPATION**  
.250(6.35) x .260(6.60) PROFILE

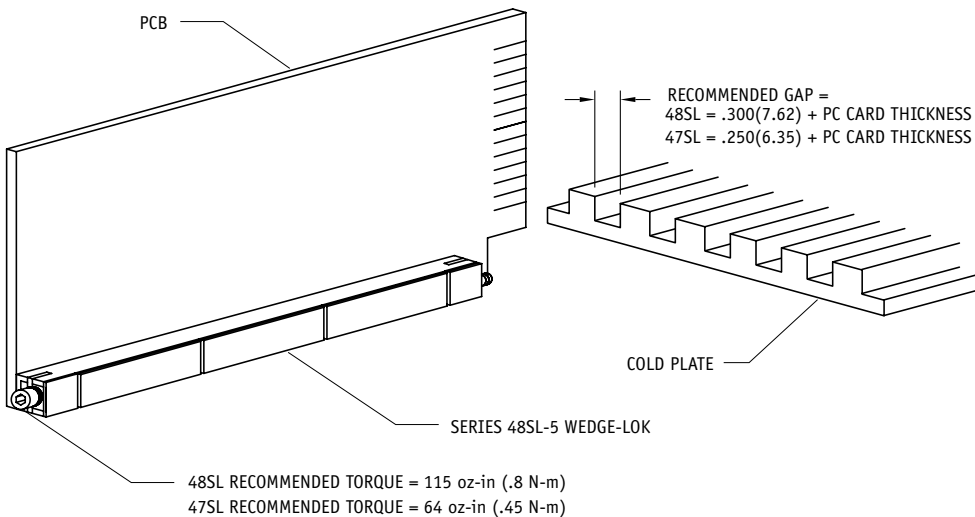
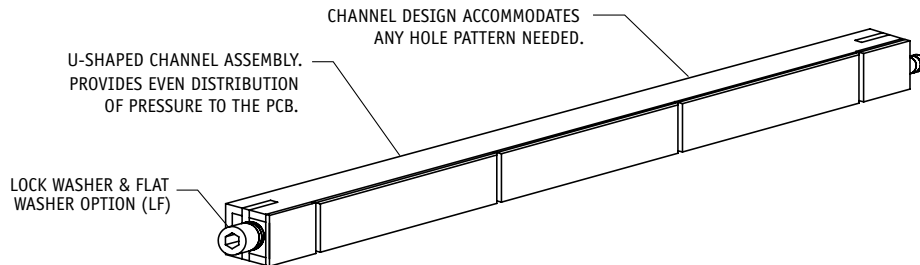

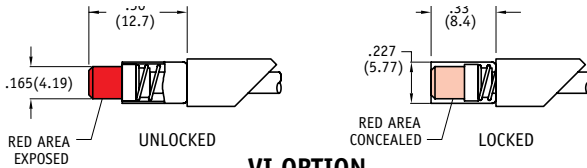

### VI OPTION

Indicates assembly is unlocked  
(adds .19 (4.8) to screw length)

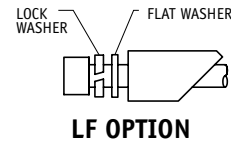

### LF OPTION

Provides additional resistance to shock and vibration  
(adds .06 (1.5) to screw length)

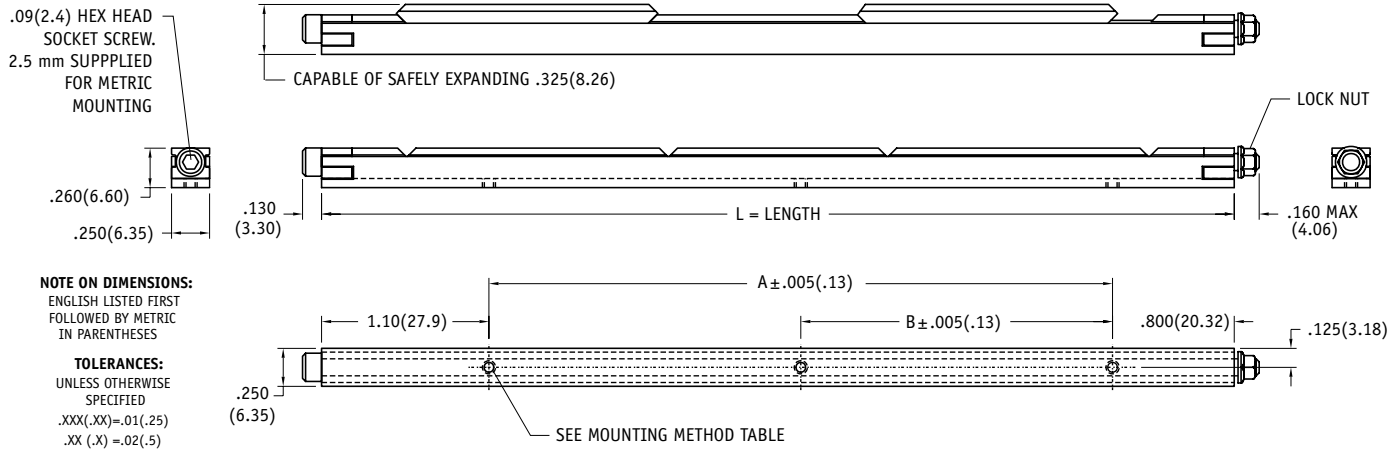

**NOTE ON DIMENSIONS:**  
ENGLISH LISTED FIRST  
FOLLOWED BY METRIC  
IN PARENTHESES

**TOLERANCES:**  
UNLESS OTHERWISE  
SPECIFIED  
.XXX(.XX) = .01(.25)  
.XX (.X) = .02(.5)

## 1 FINISH TABLE

| Code Letter | Finish (see pg.9 for RoHS Compliance)                              |
|-------------|--|
| C           | Chemical Film per MIL-C-5541, Class 1A, Gold, non RoHS compliant   |
| CC          | Chemical Film per MIL-C-5541, Class 1A, Clear                      |
| EN          | Electroless Nickel per MIL-C-26074, Class 4, Grade B, Bright       |
| N           | Nickel Plate per QQ-N-290, Class 1, Grade G, Bright (.0002")       |
| B           | Black Anodize per MIL-A-8625, Type II, Class 2, (.00005" - .0003") |
| B3          | Hard Black Anodize per MIL-A-8625, Type III, Class 2 (.002")       |
| B3D         | Hard Black Anodize with Dry Film Lube per MIL-L46010               |

## 2 MOUNTING METHOD TABLE

| DASH # | METHOD                   |
|--------|--------------------------|
| S      | #2-56 UNC-2B             |
| T      | #0-80 UNF-2B             |
| M      | Metric Screws M2.5 X .45 |
| M2     | Metric Screws M2 X .4    |

## MOUNTING DIMENSIONS

| DASH # | L            | A            | B           |
|--------|--------------|--------------|-------------|
| -48    | 4.80(121.9)  | 2.90( 73.7)  | -           |
| -50    | 5.00(127.0)  | 3.10( 78.7)  | -           |
| -55    | 5.50(139.7)  | 3.60( 91.4)  | -           |
| -58    | 5.80(147.3)  | 3.90( 99.1)  | -           |
| -60    | 6.00(152.4)  | 4.10(104.1)  | 2.05( 52.1) |
| -65    | 6.50(165.1)  | 4.60(116.8)  | 2.30( 58.4) |
| -68    | 6.80(172.7)  | 4.90(124.5)  | 2.45( 62.2) |
| -70    | 7.00(177.8)  | 5.10(129.5)  | 2.55( 64.8) |
| -75    | 7.50(190.5)  | 5.60(142.2)  | 2.80( 71.1) |
| -78    | 7.80(198.1)  | 5.90(149.9)  | 2.95( 74.9) |
| -80    | 8.00(203.2)  | 6.10(154.9)  | 3.05( 77.5) |
| -85    | 8.50(215.9)  | 6.60(167.6)  | 3.30( 83.8) |
| -88    | 8.80(223.5)  | 6.90(175.3)  | 3.45( 87.6) |
| -90    | 9.00(228.6)  | 7.10(180.3)  | 3.55( 90.2) |
| -95    | 9.50(241.3)  | 7.60(193.0)  | 3.80( 96.5) |
| -98    | 9.80(248.9)  | 7.90(200.7)  | 3.95(100.3) |
| -100   | 10.00(254.0) | 8.10(205.7)  | 4.05(102.9) |
| -105   | 10.50(266.7) | 8.60(218.4)  | 4.30(109.2) |
| -108   | 10.80(274.3) | 8.90(226.1)  | 4.45(113.0) |
| -110   | 11.00(279.4) | 9.10(231.1)  | 4.55(115.6) |
| -115   | 11.50(292.1) | 9.60(243.8)  | 4.80(121.9) |
| -118   | 11.80(299.7) | 9.90(251.5)  | 4.95(125.7) |
| -120   | 12.00(304.8) | 10.10(256.5) | 5.05(128.3) |

**Part Number Code** (See example below)

Series 48SL-5 Wedge-Lok Five-piece HTT 48SL-5 x x -x -x -x

### Optional Visual Indicator

Visual Indicator \_\_\_\_\_ VI  
None \_\_\_\_\_ [Blank]

### Mounting

Select code letter from Mounting Method Table 2 \_\_\_\_\_

### Length

In 1/10" increments \_\_\_\_\_ from -48 (4.8")  
In 2.6mm increments \_\_\_\_\_ from -48 (121.9mm)

### Finish

Select code letter from Finish Table 1 \_\_\_\_\_

### Washers

Lock Washer and Flat Washer \_\_\_\_\_ LF  
None \_\_\_\_\_ [Blank]

**Part Number Code example: 48SL-5S-48-C-LF**

Series 48SL-5 Wedge-Lok Five-piece High Thermal Transfer, 2-56 screw mount, 4.8 inches (121.9mm) long, chem film, with lock washer and flat washer