

SERIES

VIVISUN 5000™

Electro-optical display system. The day-night all weather lighting solution.

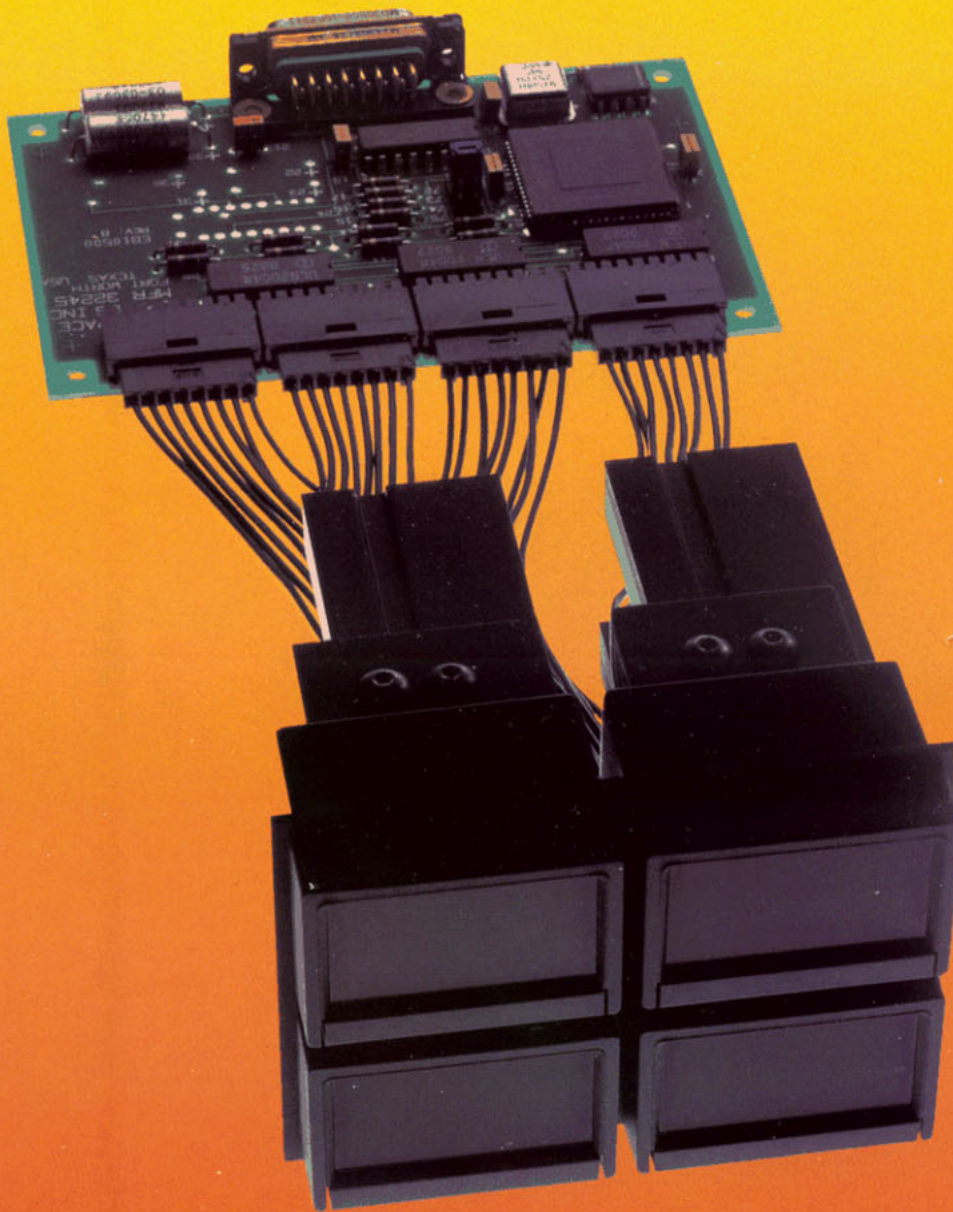

VIVISUN 5000...the complete system solution.
-NDI -Ready to use -Immediate integration

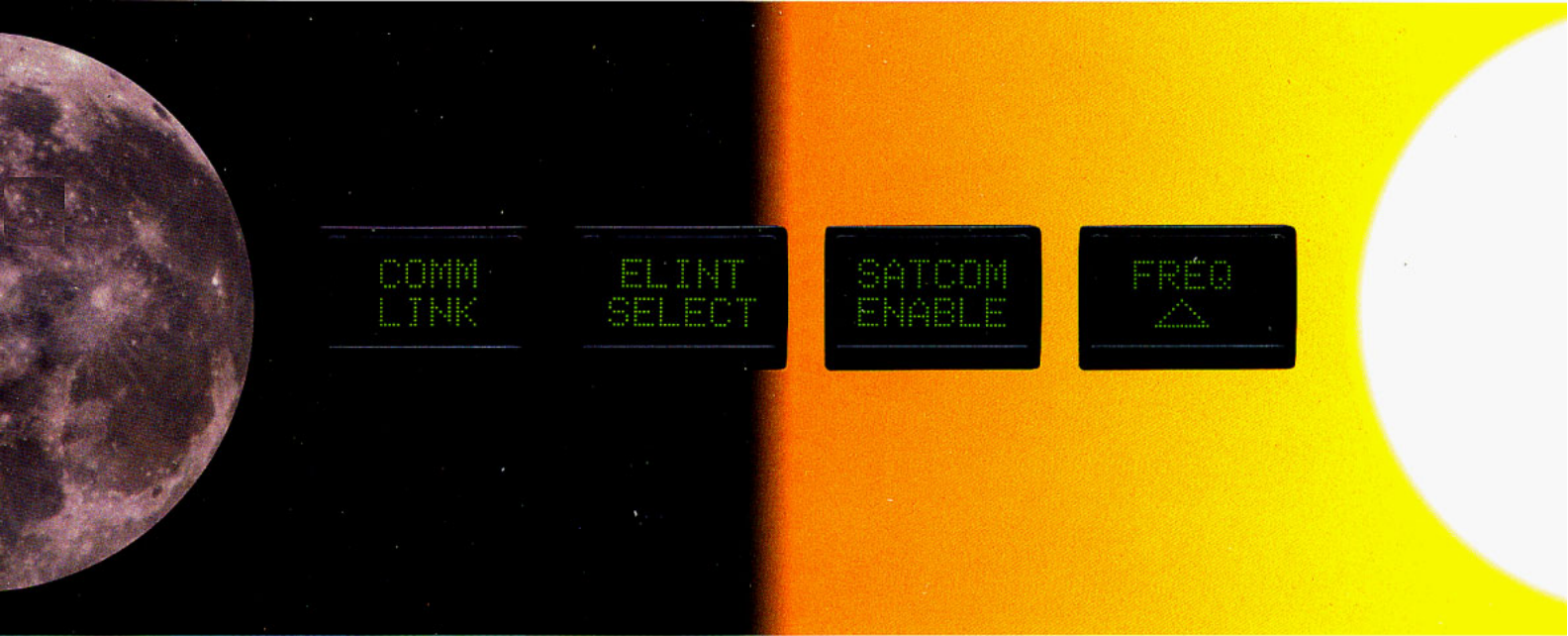

The NVIS-Sunlight Readable Electro-Optical Display System.

Aerospace Optics has long been regarded as the technical leader for NVIS/SUNLIGHT READABLE pushbutton switches. These high quality, mil-spec approved pushbutton switches have set new standards for performance in ground, shipboard and airborne military systems.

As computer controlled systems increase in complexity, their designs are limited by fixed legend pushbutton switches which perform only one function. These new designs have created man/machine interface needs that cannot be solved effectively and efficiently with single function pushbutton switches. The VIVISUN SERIES 5000 Electro-Optical Display System is the answer to this need. This Electro-Optical system provides interactive displays that are NVIS compatible and SUNLIGHT READABLE per MIL-L-85762A.

The concept

The VIVISUN SERIES 5000 Electro-Optical Display System is a completely new concept in man/machine interfacing. It is the first Electro-Optical Display to offer a system solution that is NVIS compatible, SUNLIGHT READABLE and ready to interface directly with your host computer. The system offers multifunction capabilities and virtually unlimited alphanumeric and graphic capabilities. The uniqueness of the concept is that different legends can be displayed at different times on a single interactive Electro-Optical display. This allows the host computer to offer selections to the operator who in turn can initiate action by directly actuating the Electro-Optical display. This provides an effective two-way communication link between the operator and the host computer.

A complete system

The VIVISUN 5000 is a complete ready-to-use Electro-Optical Display System consisting of four Programmable Multifunction Pushbuttons (PMP), one Refresh Processor Unit (RPU), and four cables which connect each PMP to the RPU.

The PMP display contains a dot matrix of 560 LED pixels with drive electronics, a solid state Hall effect switch and a mechanism to provide positive tactile feedback when the PMP is depressed. The Hall effect switch signals the RPU that the PMP has been actuated. The operator receives information from the host computer by the various legends presented on the PMP display which are generated by the system software. The operator initiates host computer action by depressing the PMP displaying the legend representing his selection.

The RPU contains the refresh and processing electronics necessary to function as an intelligent interface between the PMP and the host computer. It receives coded messages from the host computer and converts these messages to specific dot patterns which are displayed as legends on the PMP. When a PMP display is actuated, the RPU sends a coded message to the host computer identifying which PMP was actuated. The RPU also independently handles routine "housekeeping" functions such as self-testing, display refresh, luminance and blinking control so the host computer can concentrate on priority functions. The RPU's small size can be easily accommodated into rack mounted designs or separately mounted for severe vibration environments.

NVIS-Sunlight Readable

The VIVISUN 5000 is both NVIS compatible and SUNLIGHT READABLE per MIL-L-85762A. compatibility with these lighting extremes is accomplished through a special 1000:1 trimming ratio which provides luminance for readability in 10,000 foot-candles and the extreme low level lighting for NVIS compatibility. This unequalled lighting flexibility qualifies the VIVISUN 5000 as the lighting solution for any military application.

Rugged reliability

The VIVISUN 5000 has design features to insure

high reliability in any application. The PMP displays are designed with solid state LED's for long, reliable service. The PMP switching element is a high quality Hall effect switch with no mechanical contacts to break or wear out. The RPU components are hermetically sealed to assure reliability and long life.

The VIVISUN 5000 reliability has a calculated Mean-Time-To-Failure (MTTF) per MIL-HDBK-217E. This Electro-Optical Display System is designed to meet the rugged environmental requirements of virtually any military ground, shipboard or airborne system design.

Interactive communications

The VIVISUN 5000 provides interactive communications between the operator and the host computer. The host computer presents information to the operator by sending messages which appear as legends on the PMP displays. The operator can send a reply to the host computer by actuating the PMP displaying the desired action. The actuation signals the host computer to perform the appropriate action. New information is then presented to the operator who once again can send a reply by actuating the PMP displaying his selection. This provides the operator with interactive control over the host computer.

Reduces the number of controls

As a fully interactive Electro-Optical Display System, the VIVISUN 5000 can significantly reduce the number of dedicated controls required to interface with your system. Since each PMP can perform multiple functions, a separate switch or indicator is no longer required for each system function. Large banks of switches can be eliminated through the use of a small matrix of VIVISUN 5000 PMPs. This enables you to design control consoles that are more compact and efficient while increasing your system's capabilities.

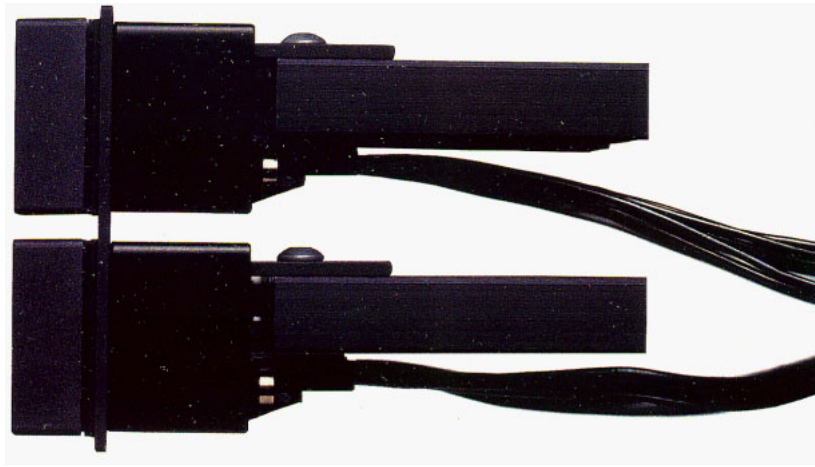
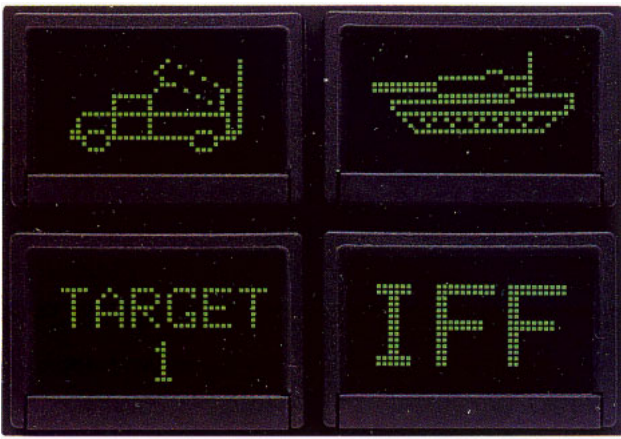

Simplifies complex panel design

Because the VIVISUN 5000 can reduce the number of components required, your control panels can be designed much smaller in size with less complexity. This results in an increase in panel space utility and an overall reduction in weight. The visual clutter caused by numerous panel controls can be greatly reduced by centralizing the VIVISUN 5000 into a small area. This reduces the operator's visual scanning area and enhances performance.

Reduces workload and stress

The VIVISUN 5000 can be programmed through the host computer to lead an operator through any sequence of events. The operator can be guided through a complete sequence of instructions or any combination of operations in a predetermined order. This can significantly reduce the stress associated with complex workloads. Bulky manuals and checkout procedures can be eliminated. As an example, in an aircraft application, the VIVISUN 5000 could be programmed to take the pilot through each mode of flight in sequence beginning with the preflight instrument checklist and ending with engine shutdown procedures.

Reduces error and reaction time

The VIVISUN 5000 significantly decreases the likelihood of operator error or oversight. Using the appropriate legends, the host computer can call for the correct responses before transmitting the next message. Priority functions can be programmed into the system so the operator can be guided quickly through any emergency situations thereby reducing reaction time. The operator cannot make an error because he is offered only the alternatives for the problem at hand excluding incorrect options.

Designed for computer based systems

The limiting factor in computer based control panels has been the communication between the computer and human operator. This communication process has been slow and difficult requiring extensive training. New technologies have forced the operator to go beyond traditional management of these control panels. For the computer to continue communications with the operator the controls must reflect changes occurring within the

system. The VIVISUN 5000 provides the needed interactive controls to communicate with the host computer more effectively than dedicated manual controls.

Maximize your computer's capabilities

The use of dedicated manual controls will not allow you to take full advantage of your computer's maximum capabilities. The task is not only to "keep the operator in the loop" but to integrate technology into the loop that keeps the operator as it's central element. Through the use of multifunction displays the VIVISUN 5000 handles the tremendous information load being supplied to the operator and allows the operator to access the maximum capabilities of the host computer.

User friendly

The VIVISUN 5000 is a complete system that is immediately ready to work for you in your application. Just provide power and serial data input/output from your personal computer which can act as a host computer. This is all that is needed to display legends and receive messages.

The Refresh Processor Unit (RPU) makes your job much easier. It acts as an interface between the host computer and the LED displays so no special display interface circuit designs are required. The RPU also includes memory capacity for performing routine "housekeeping" functions completely independent of the host computer.

The legends displayed on the Programmable Multifunction Pushbutton (PMP) are controlled by messages received from the host computer through the RPU. These messages are formed from a user friendly command structure which uses a coding system that is simple and easy to understand. You can actually create display legends on the PMP's by sending characters from the host's keyboard as you type. This can be an immense aid in your system software development. A VIVISUN 5000 software manual provides detailed information on the command structure, message coding, interface and software features.

Total legend flexibility

The ability to present any kind of legend is a key element in an interactive control environment. The PMP displays are programmable and can display text, graphics, or any combination of text and

graphics. Any visual pattern that can be drawn within the 560 pixel format can be displayed. Having flexibility like this means you can present legends in the best possible form for easy recognition.

Flicker free display

The RPU refreshes each PMP display over 400 times per second to avoid stroboscopic effects. At this rate, the human eye perceives a continuous image even if the display is moving relative to the operator. This eliminates the flicker often noticed with other electronic displays in moving vehicles such as aircraft, ships, tanks and trucks. Displays that are refreshed less than 400 times per second suffer greatly from this flickering problem and should not be used in moving vehicles.

Low touch temperature

The PMP utilizes LEDs for low power consumption and long life. The LEDs also provide low heat generation and high display clarity. Because of the low heat generation the touch temperature is much lower than most dedicated function pushbutton switches. This means that operator discomfort will not be a problem regardless of how often a switch is depressed.

Watertight and splashproof

The PMP is designed and tested to meet the watertight and splashproof requirements of MIL-STD-108. An integral rubber seal that is Permanently attached internally and a rubber sealing gasket around the front bezel prevent water from leaking through the control panel.

Positive tactile feedback

Each PMP is equipped with a mechanism which provides a positive tactile feedback force when electrical actuation is achieved. This interactive feature assures the operator by feel, as well as by sight, that actuation has occurred.

Display face actuation

The PMP is designed so that the display face can be pushed to actuate the switching function. This helps the operator readily associate the display legends with the PMP actually being depressed. A

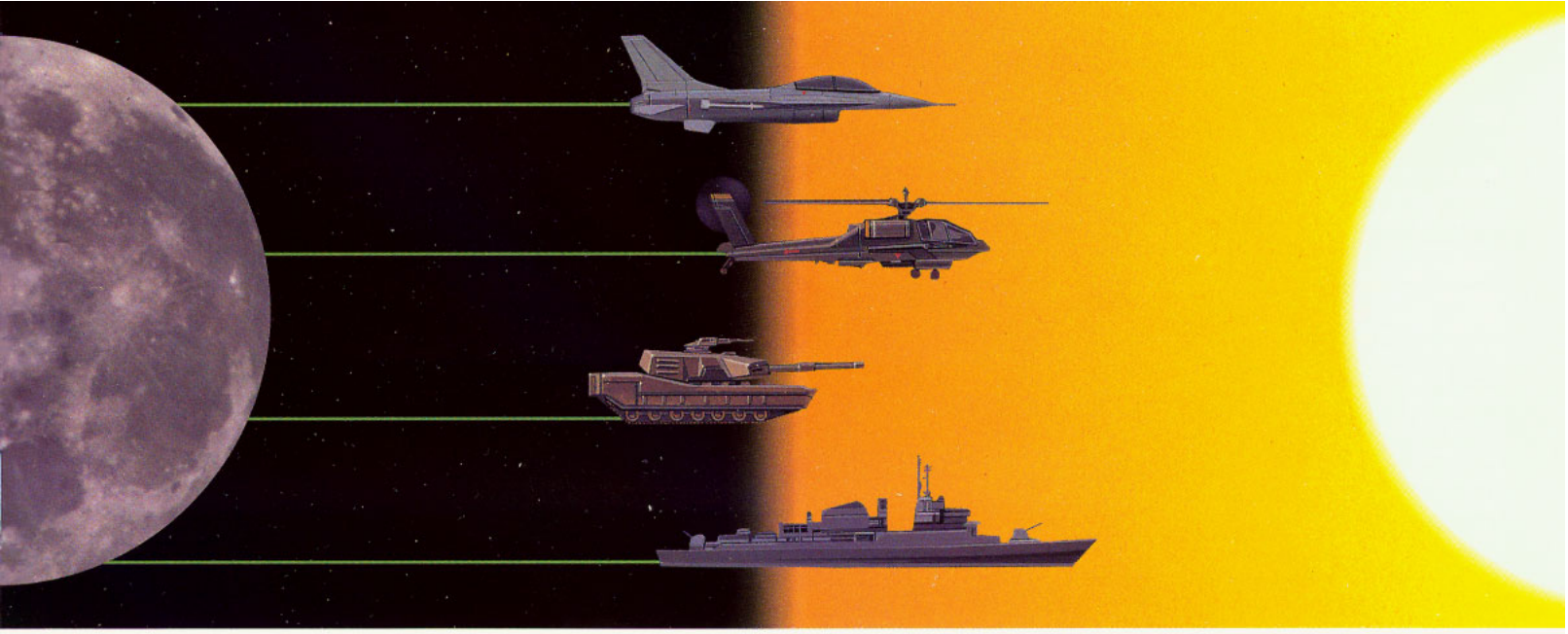

The LED Electro-Optical Display Solution for NVIS-Sunlight Requirements.

pushbar is also provided on the lower part of the display face so the operator can actuate the push-button and still read the display when necessary.

Software controlled luminance

The PMP display luminance is software controlled by the RPU in 35 brightness levels. By sending the appropriate message code to the RPU, the host computer can select any one of 35 brightness levels for excellent display visibility in ambients from darkness (including NVIS) to direct sunlight. A dimming ratio of 1000:1 allows you to match the luminance of the VIVISUN 5000 to the multi-ambient conditions of your program.

Self-testing and reporting

The RPU can conduct a series of internal diagnostic tests and report the results back to the host computer. These tests verify the proper operation of all major circuit components. The self-test is initiated at power up to identify any problems prior to the system start up. Self-test can also be performed at any other time as long as the system is operating.

Message validation

Each message received from the host computer is checked for errors and validated by the RPU before any action is taken. If the message is valid, the RPU sends an acknowledgement message back to the host computer. If the message is declared invalid, the RPU will send a retry message back to the host computer. No action is taken that would destroy existing legend information on the PMP until a message has been validated. This insures message integrity and the possibility of presenting wrong legend information is eliminated.

User-friendly software

The command structure is designed to be user friendly and easy for programming. Messages are formed by using standard ASCII character codes. The use of these familiar codes makes message coding easy to learn and easy to use.

High quality design

At Aerospace Optics we are committed to the manufacturing of high quality products. Our test lab is DESC certified and our inspection and calibration systems conform with MIL-I-45208 and MIL-STD-45662. We are a qualified products supplier for illuminated pushbutton switches and are listed on the MIL-S-22885 QPL.

Our modern facility includes a complete clean room and hybrid microcircuit manufacturing area where hybrid components are assembled under the guidelines of MIL-STD-883. Our design engineering and manufacturing operations are enhanced with Computer Aided Design (CAD) and Computer Aided Manufacturing (CAM) capabilities. Aerospace Optics has over 25 years of experience in producing cockpit controls and illuminated products for aerospace crewstations. With this extensive experience we are accustomed to developing new, state-of-the-art concepts. The VIVISUN 5000 means that tomorrow's interactive Electro-Optical Display System is available today.

Typical applications

The interactive control capabilities of the VIVISUN 5000 can greatly benefit applications where multiple controls are needed. The VIVISUN 5000 allows operators to control even the most sophisticated computerized system without the need for large and complex control panels.

Modern computer technology has enabled complex systems to be made smaller, lighter and more efficient. Computers at the heart of the system can handle even the most complicated tasks and the interactive control capabilities of the VIVISUN 5000 help improve the communications between the operator and the host computer. This will increase system effectiveness while reducing operator workload and control panel complexity.

Applications that can benefit from the use of interactive control arise in many areas, including the aerospace industry, shipboard applications, armor applications and other military systems.

Applications in the aerospace industry for fixed wing and helicopter systems include:

- Checklists
- Fault management systems
- Cockpit controls
- Flight system controls
- Navigation controls
- Weapons management
- Landing gear controls
- Advance cockpit development
- MFD support
- FLIR systems
- Automatic test equipment

Shipboard applications include:

- Steering controls
- ICOLS
- Engine controls
- Stores control
- Communications systems
- Radar systems
- Damage control systems
- Pump control room
- Arresting gear control
- Catapult systems
- Pri-Fly Control
- AFFF systems
- ASW systems

Armor and other military applications include:

- Battlefield management systems
- Secure communications systems
- Target acquisition systems
- Fire control systems
- C³I systems
- ECM systems
- IFF systems
- ELINT systems
- BITE systems
- Threat simulators
- EW simulators
- IRCM systems
- Vehicle maintenance systems

TECHNICAL DISCUSSIONS

Man machine interface

Computers have become the central point of control for almost every modern system. But with computers have come problems communicating with human operators. The VIVISUN 5000 is designed to enable computers to effectively communicate with human operators. This communication is the key to interactive control that leads to maximum system efficiency.

The first illustration in Figure A shows how a legend is presented to the operator. A coded message containing the legend information is transmitted from the host computer to the RPU via an RS-422 or RS-232 serial data link. This coded message is highly structured and contains parity information. Parity gives the RPU the ability to check the message for validity. Once the message has been validated the RPU transmits an acknowledgement message back to the host computer. If the message is declared invalid, the RPU transmits a retry message back to the host computer. No further action is taken that would destroy any existing legends until a valid message is received. This "handshaking" assures the host computer that the legend information is always true and correct. Once a message is validated the RPU converts the message into a dot pattern and turns on the appropriate pixels in the selected PMP which then displays the legend information to the operator. The RPU then awaits either an operator response or a new message from the host computer.

The second illustration in Figure A shows how an operator can send a reply back to the host computer. The operator selects the PMP displaying the legend of his choice and actuates that PMP. The PMP notifies the operator of actuation by providing an acknowledgement in the form of a tactile feedback force. At the same time the PMP sends a signal to the RPU that it has been actuated and then the RPU transmits a message to the host computer containing the identification code for that PMP.

This code is unique to the actuated PMP display so the host computer knows exactly which PMP display was actuated by the operator. The third illustration in Figure A shows how the host computer can confirm whether or not a PMP display is being held depressed. When the host computer transmits a "switch status request" command to an RPU, the identification codes of all PMP displays being held depressed are transmitted back to the host computer. This is immediately followed by an acknowledgement message notifying the host computer that the "switch status request" command has been executed. This command can be used at any time by the host computer to confirm whether or not any PMP display is being maintained in a depressed position.

The LED electro-optical display

The VIVISUN 5000 PMP utilizes Light Emitting Diode (LED) display technology. The display is comprised of 560 LED dice and support electronics assembled into a ceramic hybrid microcircuit. The LEDs are organized into a matrix of 16 rows by 35 columns. Under RPU control it can display 5 X 7 or 10 x 14 format text, graphics, or any combination of text and graphics, anywhere on the display surface.

The selection of a display technology for your application is important. Factors that should be considered during the selection process include backlighting requirements, dielectric breakdown, environmental effects upon the display, and viewing angle.

LED technology offers many advantages that include long life, low power consumption, low heat generation and high display clarity. Since LEDs are light emitters, they do not rely upon external illumination to make the display readable. LEDs operate at night without backlighting. This removes the need to have additional power sources to power the backlighting. The display color will also remain the

same, day or night.

LEDs operate on low voltages. Low operating voltages reduce the possibility of dielectric breakdown. Dielectric breakdown can be a serious reliability problem in high voltage flat panel displays and backlighting. Failures in high voltage power supplies are also eliminated with LED displays.

LED displays can be operated in high and low temperature applications. Display technologies that rely upon an electrochemical reaction may suffer permanent degradation from exposure to high temperature and ultraviolet radiation from sunlight. LEDs are not permanently degraded by either high temperature or ultraviolet radiation. Also, at low operating temperatures, LEDs operate instantly and require no warm up time.

LED displays have an inherently wide viewing angle. The viewing angle is completely independent of duty cycle, refresh rate and ambient temperature. The viewing angle of the LED is also symmetrical, providing the same viewing angle regardless of operator position.

Loop networking capabilities

In order to reduce the number of serial ports required by the host computer each RPU is equipped with networking capabilities. Instead of requiring one serial port for each RPU, the loop networking feature allows up to four RPU's to be connected to one serial port. This means that up to 16 PMPs and 4 RPUs can be handled by one serial port instead of only four PMPs and one RPU. Each of the four RPU's within a network has its own unique address code. Figure B shows the serial data line interconnections and the RPU address codes used to communicate with up to 4 RPUs and 16 PMP displays from one host computer serial port.

Each RPU is jumper configured with a unique address code from Address 0 to Address 3 prior to network installation. Legend commands sent from

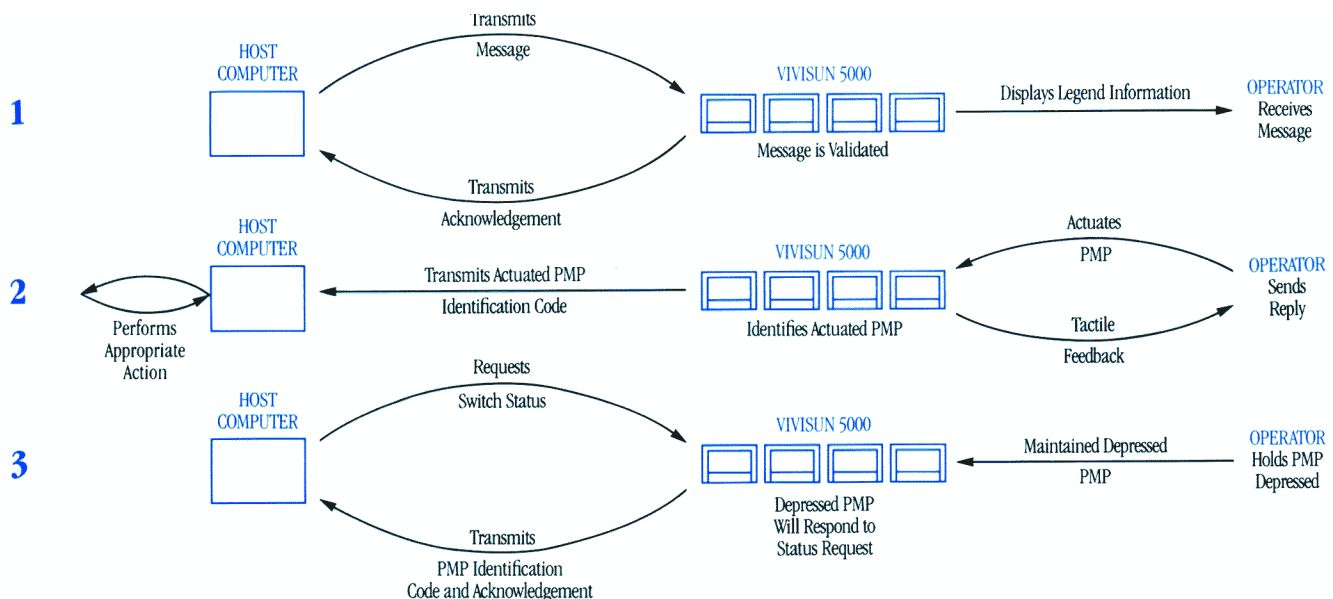

FIGURE A

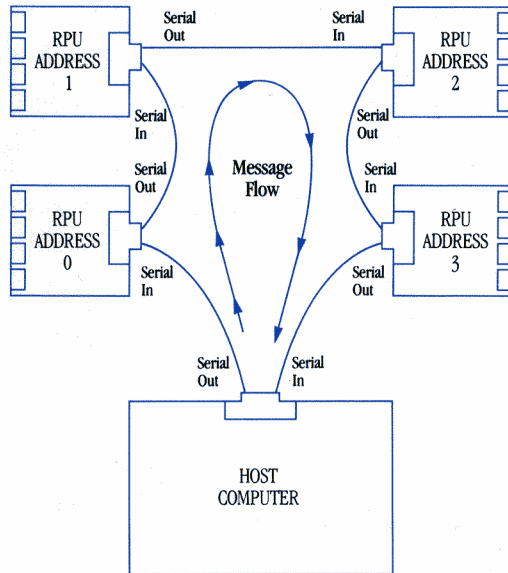

FIGURE B

the host computer are coded with address information showing the destination RPU and PMP display. Messages not addressed for a particular RPU are ignored and simply retransmitted down the loop to the next RPU. As an example of this process, the host computer would transmit a message to the network coded for RPU Address 3. This message first arrives at RPU Address 0. RPU Address 0 would compare the message address with its jumper setting and find that the message is coded for RPU Address 3. RPU Address 0 then ignores the message and retransmits the entire message to RPU Address 1. This compare and retransmission process occurs again from RPU Address 1 to RPU Address 2 and from RPU Address 2 to RPU Address 3. When RPU Address 3 checks the message, it finds that the message address corresponds to its jumper address setting. RPU Address 3 now not only echoes the command back to the host computer, but checks the message for validity, sends an acknowledge back to the host computer and executes the command. All other RPUs and PMPs within the network remain unchanged.

When one of the 16 PMP displays is actuated the RPU controlling it is notified. That RPU then transmits an actuation message containing the PMP identification code to the host computer. The PMP identification code is determined by the RPU address code and the RPU connector to which it is connected. The PMPs have no individual coding and any PMP can be connected to any RPU.

Software features

The software command structure of the RPU is designed to make legend generation flexible and efficient. The command set is divided into two groups, Global and Specific. Global commands affect all RPUs and PMPs within the network while Specific commands apply only to one RPU or PMP.

Global commands are designed to be a "short cut" for commands of a general nature. They allow attributes such as blink timer synchronization, luminance control, switch status checks, and clear all displays. The blink synchronization command

assures that all PMP displays within a network will blink in unison. The switch status check is used to determine whether or not any PMP display is being held depressed. The clear all displays command allows a quick initialization of all network RPUs and PMPs during system power up. The luminance control command allows the intensity level of all network PMPs displays to be adjusted simultaneously.

Specific type commands are directed at a single RPU or PMP. These commands control such attributes as self-test, all pixels on, blinking, text formats and graphics modes. The self-test feature performs an RPU self-test and the results of the self-test are transmitted to the host computer. The all pixels on command enables the operator to visually verify proper operation of the display on the selected PMP. The blinking and clear display commands are also directed to a specific PMP. In the text mode, the RPU provides both a 5 X 7 and a 10 X 14 character format. In graphics mode, PMP pixels can either be controlled individually or in horizontal or vertical line groups.

The RPU allows legends to be presented on the PMP display in more than one mode simultaneously. For example, text legends can be displayed and later updated with an underscore or surrounded by a box.

All commands and legend control statements are within the ASCII (American Standard Code for Information Interchange) character set. ASCII coding allows commands to be entered on a standard computer keyboard. Legend control statements will also be visible within source code listings. The ASCII command structure helps programmers become familiar with the command set quicker because messages can be developed and sent to the VIVISUN 5000 using a personal computer.

Human factors

Human factors are important considerations in system design. Human factors most often affecting programmable switch design include the display size, display resolution, character height, refresh

rate, fingerprints and tactile feedback. Software features and attributes are important to provide flexibility in legend presentation.

It is important that the overall programmable display size be large enough to be seen and actuated easily. Text characters and graphics patterns must be large enough to be visible at a typical viewing distance of 28-30 inches. Extremely small characters may be difficult to read at this distance and should be avoided. To provide good operability, the PMP has an overall size of 1 X 1.5 inches. The display resolution is optimized at 40 pixels per inch yielding a minimum character height in the 5 x 7 text format of .162 inch.

Displays that require periodic refresh must be refreshed at a rate in excess of 400 frames per second. This will prevent stroboscopic "flickering" of the display during the vibration often encountered in aircraft and vehicular applications. The RPU in the VIVISUN 5000 refreshes each PMP display in excess of 400 frames per second, high enough to eliminate stroboscopic effects.

Since the face of a programmable display is designed to be touched during actuation, it must be resistant to scratches and fingerprints. Antireflective coatings on optical filters may be unsuitable for programmable display applications due to scratching and the serious performance degradation caused by fingerprints. The face of each VIVISUN 5000 interactive PMP display is treated with a unique process that resists scratches and fingerprints.

The actuating surface of a programmable display must provide a positive tactile feedback for operator acknowledgement when actuated. It must also provide a degree of protection against accidental actuations. The tactile feedback should remove any need for the operator to visually read the display to determine whether or not it was actuated. The VIVISUN 5000 PMP provides both a positive tactile feel and integral actuation barriers. The sides and top of the PMP display form a raised area forming an actuation barrier. This helps prevent multiple actuation should the operator's finger slip off of the PMP face during actuation.

The PMP has a push face design with a pushbar on the lower part of the display face. Depressing the pushbar results in an actuation force of 1-3 pounds. Using the pushbar enables the operator to view the display during actuation when required. Depressing the center of the display face results in an actuation pressure of 2-6 pounds. This extra pressure in conjunction with the integral actuation barriers reduces the possibility of an accidental actuation should a PMP be unintentionally bumped.

The RPU has many software attributes that provide flexibility in legend presentation. Text and graphics patterns may be displayed together on the same display face. This gives the designer the ability to present text legends and later update these legends with graphics attributes such as an underscore or surrounding box. This enables the operator to know at a glance when a legend representing a system feature is selected or available. For prompting and warning, the RPU provides a blinking attribute.

TECHNIQUES FOR USE

The full potential of the powerful VIVISUN 5000 will not be realized if it is used to simply replace a single, dedicated function switch. To use its full capabilities, careful planning needs to be performed early in the design process. The VIVISUN 5000 can then be part of a totally integrated system. To plan and organize the control of a system, a flow chart can be used to illustrate the control flow. This enables you to visualize the control flow easily without the need to program the host computer.

Control planning can be divided into three simple steps:

1. **IDENTIFY** all system functions that are to be controlled with the VIVISUN 5000.
2. **GROUP** these functions into functionally related control groups or menus.
3. **ORGANIZE** the control groups to form a control scheme.

When a control system is planned properly, the control flow will be straightforward and easy to understand.

An applications example

The following applications example illustrates how only one VIVISUN 5000 system could be used to control all major systems on an advanced aircraft. Each row of the chart shows the legend information displayed on each of the four PMP displays as it is presented to the pilot. Solid blue lines originating from a PMP display indicate actuation of that PMP display. Dotted lines originating from a PMP display indicate that the legend information changed as the result of actuation of another PMP display. Arrows are used to indicate the direction of the control flow.

The example shown incorporates both multilegend and multifunction modes of operation. PMP displays are used to display system status, perform interactive checklists and directly control system functions.

When the pilot first activates the host computer, the legend information in row 1 is displayed. The legends indicate that the battery, fuel and breathing oxygen levels are within system limits and that the engine can now be started. The pilot would then actuate the "ENGINE START" display and once the engine was started, the system computer would perform an automatic test of all engine, hydraulics and power systems. Since all systems are within safe limits, the pilot actuates the "CHECK LIST" display causing the checklist shown in row 3 to be presented. The pilot acknowledges each requested check by actuating the appropriate PMP display. When actuated, each display face would go blank until the entire checklist is complete. In this example, only wing ice, flaps position, and brakes are included within the checklist. System status is also shown during the checklist operation, the result of continuous system diagnostics. If any fault were to occur, legends would appear indicating the type of fault and suggested remedies. In this example, all systems are "OK." Once complete, the "FLIGHT MENU" legend is displayed, allowing the pilot to enter the aircraft systems control menu. When actuated, the flight menu is displayed, shown on row 5.

The "FLIGHT MENU" is the origin for all electronic warfare, weapons, system control and diagnostics functions. By actuating the "EW MENU" display in row 5, the pilot can select active jamming, passive radar warning receivers, and defensive chaff shown in row 6. Whenever a system is activated, the "ARMED" legend appears. When actuated, legends are designed to "toggle" between armed and unarmed states for simplicity. When the pilot returns by actuating the "FLIGHT MENU" display in row 7, arrowhead symbols are used to show that at least one of the menu's selections are armed. This lets the pilot know at a glance that he has made a selection within that menu. The same control scheme is used for weapons in rows 9 and 10 after the "WEAPON MENU" display is actuated in row 8. In a real application, the host computer would be programmed to recognize the attached weapons and provide all necessary launch sequence and targeting instructions to the pilot.

Actuating the "SYSTEM CHECK" display in row 11 causes a manual systems diagnostics of major systems to be shown in row 12. This can be performed at any time to confirm status of the engine, hydraulics and power systems. In row 13, the pilot actuates the "SYSTEM MENU" display. In this menu, the pilot can stop and start the aircraft engine as well as manually switch between main and backup hydraulics and power. In row 15, the pilot has actuated the "FLIGHT MENU" display to return to the flight menu shown in row 16. Note that all electronic warfare and weapon systems are now unarmed. To prevent accidental weapons release, the host computer disarmed these systems automatically when the engine was stopped in row 14. This feature, although only an example, can be used to increase system safety by using the host computer to prevent unsafe operating modes.



COPYRIGHT 1993 by AEROSPACE OPTICS, INC. All rights reserved. No part of this book, except page 7, may be reproduced in any form, by mimeograph or any other means without the written permission of Aerospace Optics, Inc.

The worksheet shown on page 7 is provided as a pattern so copies may be made to assist you in planning and organizing your system control flow chart.

VIVISUN 5000
Interactive Control Worksheet

Line _____

Line _____

Line _____

Line _____

Line _____

Line _____

Line _____

Line _____

Graphics
Template

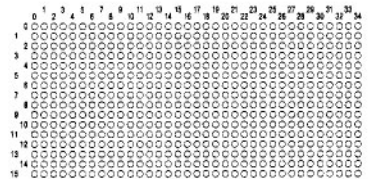
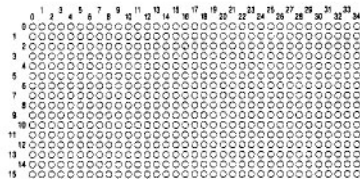
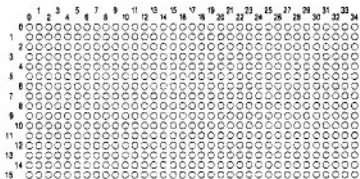



SPECIFICATIONS

MECHANICAL FEATURES:

PROGRAMMABLE MULTIFUNCTION PUSHBUTTON (PMP):

Packaging Dimensions: The PMP display construction, physical dimensions and configuration conform to Figure 1.

Low Weight: 75 grams maximum including mounting sleeve and heatsink.

Length: Overall length is 3.25" including the heatsink.

Mounting Depth: The depth behind a .06" panel is 2.76" including the heatsink.

Housing Material and Finish: Plastic, black matte finish.

Heatsink Material and Finish: Aluminum, black anodized.

Pushbutton Action: Momentary.

Mechanical Life: 250,000 cycles.

Operating Characteristics:

Actuation travel: .040" \pm .010"

Actuation force: 1 to 3 pounds when depressing the pushbar.

2 to 6 pounds when depressing the display screen.

Strength of Actuator: 18.7 pounds static load.

Tactile Feedback: A positive tactile feedback force is provided when electrical actuation is achieved.

Mounting Sleeve: A mounting sleeve is provided with two captive slot head mounting screws installed.

Mounting Sleeve Material: Corrosion resistant steel.

Mounting Plate Thickness: The mounting sleeve allows the PMP display to be installed on mounting plates ranging from .062" to .125."

Mounting Cutout Dimensions: See Figure 2.

Mounting: The PMP display is mounted by removing the mounting sleeve, inserting the PMP display through the mounting plate cutout then replacing the sleeve and tightening the captive screws from the back.

Heatsink: A heatsink is provided to minimize the display temperature and is designed so that the mounting hardware can be removed and installed without removing the heatsink.

Sealing: The PMP display is supplied with an integral rubber seal permanently attached internally and a rubber sealing gasket around the edges of the front bezel.

Enclosure Design: Dripproof, watertight and splashproof when the rubber sealing gasket is properly installed.

Dripproof Sealing: There is no leakage of water through the seals when subjected to the dripproof sealing test defined in MIL-S-22885 para. 4.8.20.3 and MIL-STD-108.

Watertight Sealing: There is no leakage of water through the seals when subjected to the watertight sealing test defined in MIL-S-22885 para. 4.8.20.2 and MIL-STD-108.

Splashproof Sealing: There is no leakage of water through the seals when subjected to the splashproof sealing test defined in MIL-S-22885 para. 4.8.20.1 and MIL-STD-108.

REFRESH PROCESSOR UNIT (RPU):

Packaging Dimensions: The RPU physical dimensions are as shown in Figure 3.

Weight: 85 grams excluding interconnecting cables.

Mounting: Mounting holes are provided on the RPU.

System Interface Connector: The RPU system connector is a male 15 pin D-style subminiature connector.

PMP Connector: The RPU to PMP connectors are 8 pin Amp Mod. IV.

CABLES:

Dimensions: The cable dimensions are shown in Figure 4.

Connector: The cable connectors are 8 pin AMP Mod. IV.

Weight: 23 grams typical.

Connector Retention: 5 pounds, per MIL-STD-202, method 211A, test condition A.

FIGURE 1
PMP DIMENSIONS

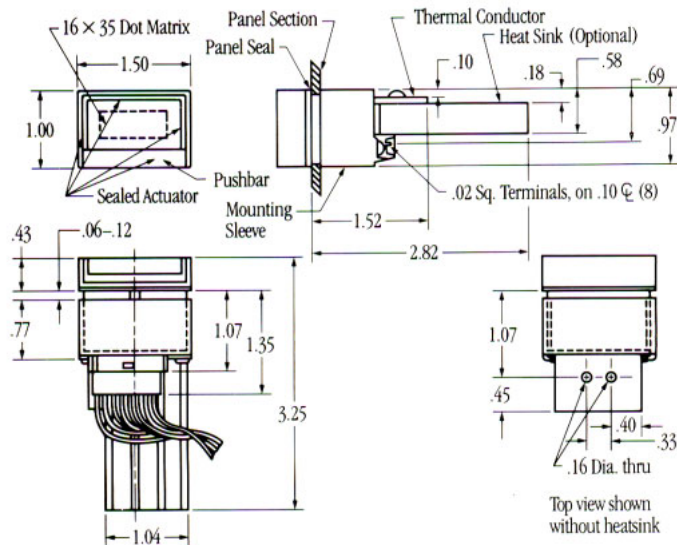

FIGURE 2
PANEL MOUNTING CUTOUTS AND SPACING

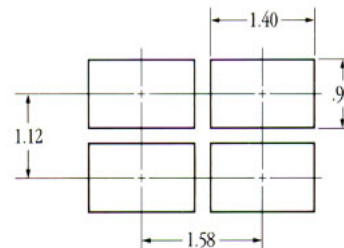

FIGURE 3
RPU DIMENSIONS

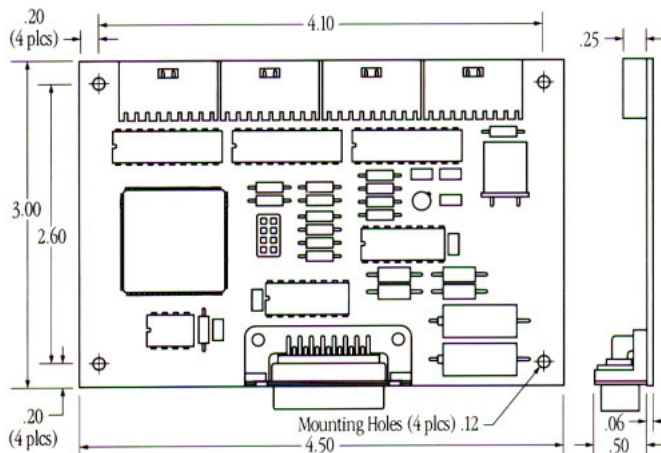
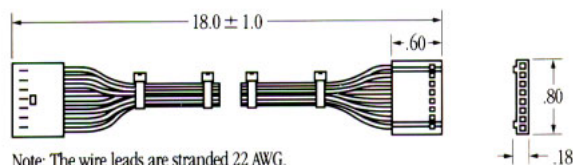

FIGURE 4
CABLE DIMENSIONS





ELECTRICAL FEATURES:

PROGRAMMABLE MULTIFUNCTION PUSHBUTTON (PMP):

Display Supply Voltage: 5 VDC (+0.5V, -0.0V).

Display Supply Current: 850 MA. maximum.

Display Drive Current: The average forward drive current of each LED at full brightness is 1.5 MA.

Display Power Dissipation: 1.20 Watts typical with 25% of the LEDs energized at full brightness.

Electrostatic Discharge: 20,000 Volts measured between the front bezel and the mounting plate.

Insulation Resistance: 1000 Megohms minimum at 500 VDC.

Dielectric Withstanding Voltage: 500 VAC, 60 Hz.

Reliability: The minimum PMP Mean-Time-To-Failure (MTTF) as calculated per MIL-HDBK-217E, Notice 1 at a pixel loading of 25% is as follows:

Environment	Temperature	MTTF (Hours)
Ground Benign	35°C	350,000
Naval Sheltered	45°C	70,000
Airborne Inhabited Fighter	60°C	22,000

REFRESH PROCESSOR UNIT (RPU):

Electrical Interface: The RPU communications interface meets the requirements of EIA RS-422.

Optional RS-232C Interface: The optional RS-232C serial communications interface transmits and receives data conforming to the EIA RS-232C standard.

RPU Supply Voltage: +5VDC (± 0.25 VDC). RPU supply voltages below 4.75VDC result in an automatic RPU reset.

RPU Power Dissipation: 1.0 Watt maximum.

Connector Pinouts: The pinouts for the male 15 pin D-style subminiature connector are identified in Figure 5.

Baud Rate: The asynchronous serial communications rate between the RPU and host computer is selectable between 2.4K, 4.8K, 9.6K, and 19.2K baud.

Baud Rate Selection: The baud rate is selectable according to the jumper settings shown in Figure 6.

Serial Transmission Format: The asynchronous serial data transmissions between the RPU and the host computer are comprised of 1 start bit, 7 data bits, 1 odd parity bit and 1 stop bit.

Message Validation: Each message sent from the host computer to the RPU is tested for parity and syntax before being displayed.

Error Reporting: The result of the RPU message validation is reported back to the host computer.

RPU Capacity: Each RPU can drive up to four PMP displays.

Multiple RPUs: A loop networking feature allows up to four RPU boards to be connected together in a daisy chain so that only one host computer serial port is required to drive up to sixteen PMP displays.

RPU Address Coding: The RPU loop networking address codes are jumper selectable according to Figure 7.

Self Testing: The RPU executes internal diagnostics tests to verify operation of major circuit components.

Hall Effect Switch Functions: The Hall effect switch within the PMP is a low power solid state device designed to signal the RPU that the PMP display has been actuated. It is not designed to switch electrical loads.

Acquisition Transmits Code: Upon actuation of a PMP display, the Hall effect switch signals the RPU which then transmits a unique serial data character to the host computer identifying the PMP that was actuated.

Continuous Depression Confirmation: The host computer can poll the RPU to determine if any of the PMP displays are being continually depressed.

Display Refresh Rate: The RPU refreshes the PMP displays in excess of 400 times per second completely independent of the host computer.

Reliability: The minimum RPU Mean-Time-To-Failure (MTTF) as calculated per MIL-HDBK-217E, Notice 1 is as follows:

Environment	Temperature	MTTF (Hours)
Ground Benign	35°C	320,000
Naval Sheltered	45°C	180,000
Airborne Inhabited Fighter	60°C	120,000

VIVISUN 5000 System: A complete VIVISUN 5000 electro-optical display system is shown in Figure 8.

FIGURE 5
CONNECTOR PINOUTS

RS-422	
1	- Serial input to RPU
2	+ Serial input to RPU
3 and 4	NC
5	+ Serial output from RPU
6	- Serial output from RPU
7 and 8	NC
9,10,11	Power Ground
12 and 13	+ 5VDC logic power input
14 and 15	+ 5VDC display power input
RS-232C	
1	Serial input to RPU
2,3,4,5	NC
6	Serial output from RPU
7 and 8	NC
9,10,11	Power and signal ground
12 and 13	+ 5VDC logic power input
14 and 15	+ 5VDC display power input

FIGURE 6
BAUD RATE JUMPERS

BaudRate	Jumper 72	Jumper 73
19.2K	Open	Open
9600	Closed	Open
4800	Open	Closed
2400	Closed	Closed

Note: The baud rate jumper setting is read by the RPU only during power up.

FIGURE 7
ADDRESS CODE JUMPERS

Address Code	Jumper 74	Jumper 75
0	Closed	Closed
1	Open	Closed
2	Closed	Open
3	Open	Open

Notes: 1. No two RPU boards in a loop network may have the same address code.
2. All RPU boards connected in a loop network must have the same baud setting.

FIGURE 8
VIVISUN 5000
COMPLETE SYSTEM

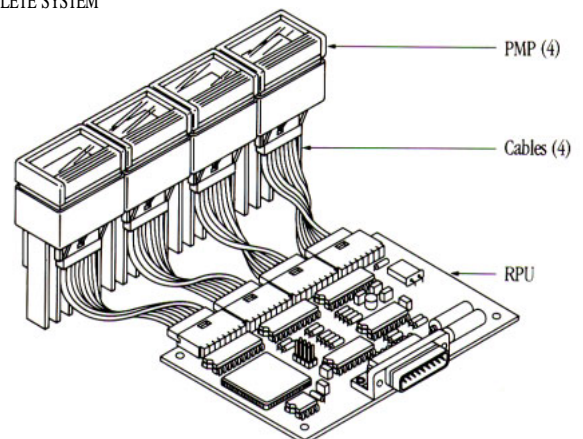



VISUAL FEATURES:

DISPLAY EMISSION CHARACTERISTICS:

Display Illumination: The VIVISUN 5000 display is illuminated by a matrix of Light Emitting Diodes (LEDs) for high reliability.

Chromaticity Coordinates: See Figure 9 for limits.

Color	x	y
Green	.419	.578

Average Display Luminance: 150 foot-lamberts minimum at 25°C.

Dimming Ratio: 1000 to 1 from approximately 0.15 foot-lamberts to 150 foot-lamberts at 25°C.

Luminance Control: The display luminance is adjusted by software control in 35 brightness levels from minimum luminance to maximum luminance.

LED Uniformity: The luminance of each LED within the display matrix is no less than 40% of the average luminance of all LEDs in the display.

Display Refresh Rate: The display is refreshed in excess of 400 times per second.

Viewing Angle: The display viewing angle is 45 degrees.

NVIS COMPATIBILITY:

NVIS Compatibility: The VIVISUN 5000 complies with the NVIS radiance requirements of MIL-L-85762A.

Type I Class A NVIS Radiance: Less than 1.7×10^{-10} at a display luminance of 0.1 foot-lamberts per MIL-L-85762A.

Type II Class B NVIS Radiance: Less than 1.6×10^{-10} at a display luminance of 0.5 foot-lamberts per MIL-L-85762A.

Spectral Radiance: Figure 10 shows the normalized spectral radiance of the VIVISUN 5000 PMP, the relative photopic response and the relative spectral response of the Class A and Class B NVIS.

Display Uniformity: The average luminance ratio of a VIVISUN 5000 display is within a 2:1 ratio of the average luminance of other VIVISUN 5000 displays.

SUNLIGHT READABILITY:

Display Appearance: The LEDs produce a high clarity display that is extremely readable in darkness as well as daylight.

Minimum Difference Luminance: When set to full brightness, the VIVISUN 5000 displays comply with the minimum difference luminance requirement of 100 foot-lamberts for alphanumeric displays per MIL-L-85762A.

Sunlight Readability: When set to full brightness the display is readable in 10,000 foot-candles of diffuse illumination and meets the sunlight readability requirements of MIL-L-85762A for illuminated visual signals excluding reflected specular sunlight.

Contrast: Contrast is measured in accordance with the sunlight readability test procedures of MIL-S-38039 and the test setup shown in Figure 11. The minimum contrast values are:

Diffuse Ambient Illumination in Foot-Candles	Contrast On/Off C_o	Contrast On/Background C_i	Contrast Off/Background C_{oL}
10,000	3.0	3.0	≤ 0.25

where:

$$C_o = \frac{L_2 - L_1}{L_1} \quad C_i = \frac{L_2 - L_3}{L_3} \quad C_{oL} = \frac{L_3 - L_1}{L_1}$$

- L_1 = Average background luminance including unlit display image elements
- L_2 = Average luminance of activated display image element
- L_3 = Average luminance of deactivated display image element
- C_o = On/Background contrast
- C_i = On/Off contrast
- C_{oL} = Off/Background contrast (≤ 0.25 for alphanumeric displays per MIL-L-85762A)

E = 10,000 foot-candle light source
P = Photometer

FIGURE 9
CHROMATICITY COORDINATES

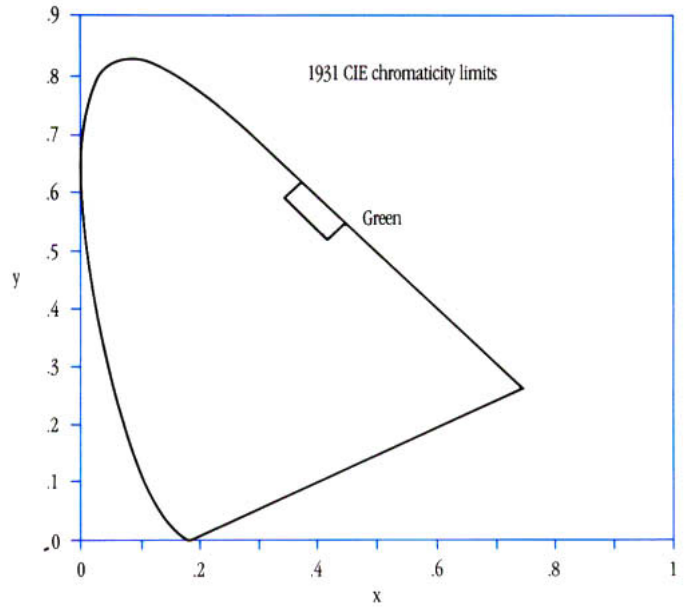

FIGURE 10
PMP SPECTRAL RADIANCE

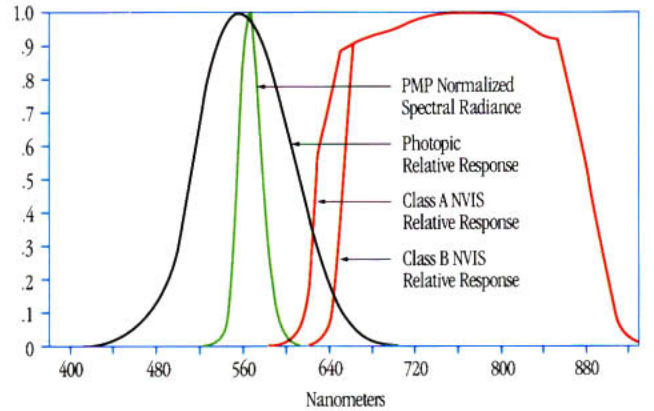
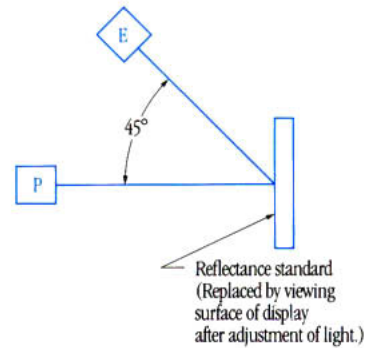

FIGURE 11
CONTRAST MEASUREMENT



E = 10,000 foot-candle light source
P = Photometer



DISPLAY IMAGING CHARACTERISTICS:

Pixel Array: The 560 LED pixels are arranged in a dot matrix array of 16 rows by 35 columns.

Pixel Size: The LED image elements are typically .012" by .012."

Pitch: The centerline spacing of each imaging element is .025."

Resolution: 40 lines per inch.

Active Display Area: The active area size of the 560 pixel array is .387" by .862."

Character Capacity:

Two rows of six characters in a 5 x 7 format.

One row of three characters in a 10 x 14 format.

Character Size: See Figure 12.

Character Format	Size
5 x 7	.162 x .112
10 x 14	.337 x .237

SOFTWARE CONTROLLED LEGEND CAPABILITIES:

Character Style: The dot matrix patterns for the internally generated 5 x 7 and 10 x 14 formats are shown in Figure 13.

Character Positioning: The internal software allows X and Y positioning of legends anywhere in the active display area.

Lines: Horizontal and vertical lines can be displayed in any length and in any position in the active display area.

Graphics Patterns: The LED pixels can be individually controlled so that any graphics pattern that can be drawn within the 560 pixel array can be displayed.

Blinking: Legends can be controlled to start or stop blinking at a rate of 1.5 Hz.

ENVIRONMENTAL CONDITIONS:

Temperature:

Operating	- 40°C to + 71°C
Non-Operating	- 55°C to + 85°C

Military Temperature Range: The operating temperature range of the VIVISUN 5000 system is compatible with the following military electronic equipment specifications:

Military Equipment Specification	Operating Conditions
MIL-E-4158	Temperate, desert and tropical
MIL-E-5400	Class 1B
MIL-E-16400	Ranges 2, 3 and 4

High Temperature: In accordance with MIL-STD-810C, method 501.1, procedure I or procedure II, +71°C maximum, operating.

Low Temperature: In accordance with MIL-STD-810C, method 502.1, procedure I, -40°C, operating.

Thermal Shock: In accordance with MIL-STD-810C, method 503.1, procedure I, -55°C to +85°C, non-operating.

Shock: In accordance with MIL-STD-810C, method 516.2, procedure IV, 75G, 6ms.

Vibration: In accordance with MIL-STD-810C, method 514.2, procedure I, curve H.

Relative Humidity: In accordance with MIL-STD-810C, method 507.1, procedure I, 85% to 95% Relative Humidity for 10 days.

Fungus: In accordance with MIL-STD-810C, method 508.2.

FIGURE 12
CHARACTER SIZES

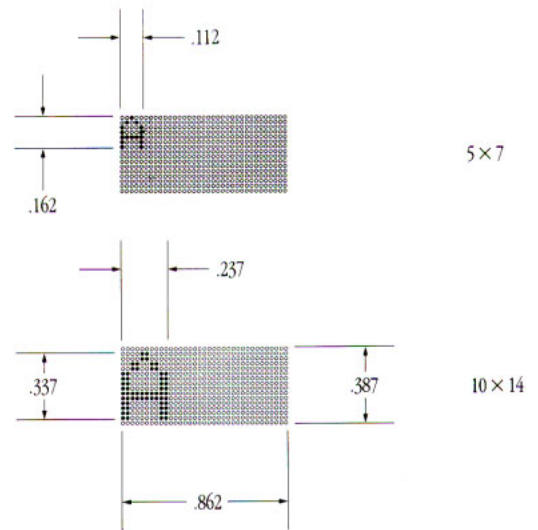
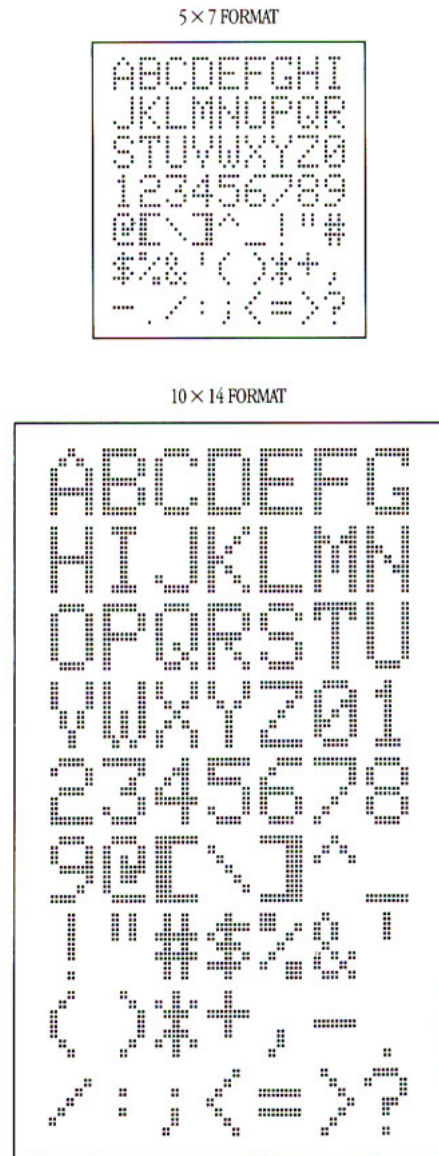
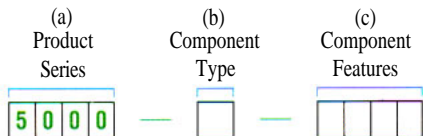

FIGURE 13
CHARACTER STYLES



HOW TO ORDER THE VIVISUN SERIES 5000 ELECTRO-OPTICAL DISPLAY SYSTEM



The VIVISUN 5000 components are specified by a 9 character part number which is comprised of (a) 4 digits to define the Aerospace Optics VIVISUN SERIES 5000 product line, (b) 1 character to define the component type and (c) 4 digits to define the specific component features.

To specify a VIVISUN SERIES 5000 component, determine the part numbers as follows:

Step 1: Begin the part number with 5000 to identify the product series.

Step 2: Select the desired components type from Table 1 and insert the appropriate designation into the fifth position of the 9 character part number.

Step 3: Select the desired component features from Table 2 and enter this code as the last four digits in the part number.

Note: Dashes are used to separate the product series number, the component type designation and the features code.

TABLE 1 Component Types	R-Refresh Processor Unit (RPU)	P-Programmable Multifunction Pushbutton (PMP)	C-Cable
----------------------------	--------------------------------	---	---------

TABLE 2 Component Features	Refresh Processor Unit (RPU)	Feature			Component Ordering Code
		Interface	Baud	Address	
		RS-232C	19.2K	0	5510
		RS-422	19.2K	0	5520
	Programmable Multifunction Pushbutton (PMP)	Green			5551
	Cable Assembly	18 inches in length			1118

Listing of Part Numbers

Description	Part Number
Refresh Processor Unit (RPU), RS-232C, factory preset to 19.2Kbaud, Address 0	5000-R-5510
Refresh Processor Unit (RPU), RS-422, factory preset to 19.2Kbaud, Address 0	5000-R-5520
Programmable Multifunction Pushbutton (PMP), Green	5000-P-5551
Cable, for interconnecting PMP to RPU, standard type, 18 inches in length	5000-C-1118

A complete VIVISUN SERIES 5000 Electro-optical Display system consists of one Refresh Processor Unit (RPU), four Programmable Multifunction Pushbuttons (PMP) and four Cables.

All RPU circuit boards are shipped factory preset at a baud rate of 19.2K baud and loop network address 0. Other baud rates and network addresses are easily configured by changing the jumper settings.



ORDERING OPTIONS:

Option 1

How to order a complete VIVISUN SERIES 5000 ELECTRO-OPTICAL DISPLAY SYSTEM with [RS-232C](#) interface:

<u>Part Number</u>	<u>Quantity per System</u>
5000-R-5510	1
5000-P-5551	4
5000-C-1118	4

Option 2

How to order a complete VIVISUN SERIES 5000 ELECTRO-OPTICAL DISPLAY SYSTEM with [RS-422](#) interface:

<u>Part Number</u>	<u>Quantity per System</u>
5000-R-5520	1
5000-P-5551	4
5000-C-1118	4



AEROSPACE OPTICS INC.

3201 Sandy Lane, Fort Worth, Texas 76112
(817) 451-1141 • Fax (817) 654-3405